

FADAL

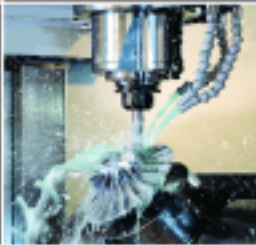

VMC 6030
Vertical Machining Center
Fadal MP CNC Control

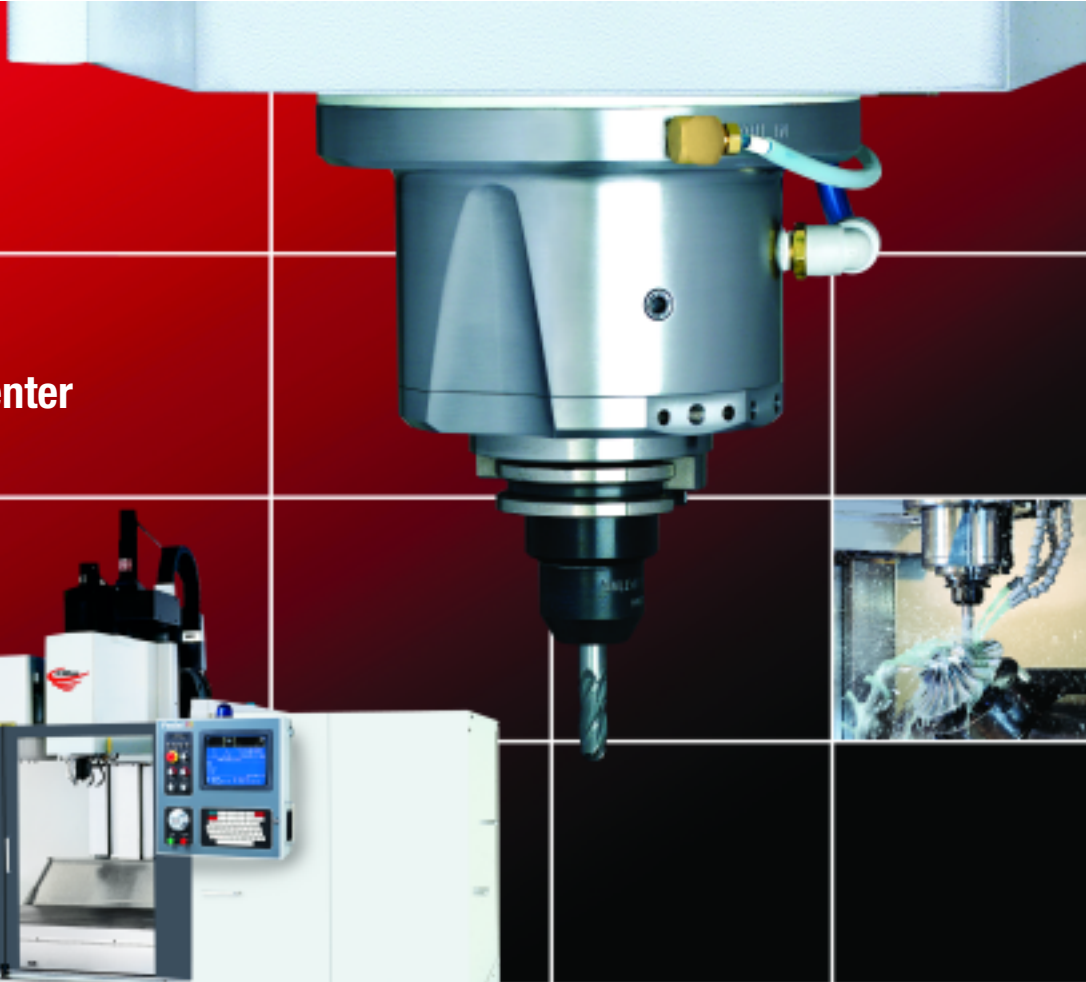

FADAL MACHINING CENTERS

Blue Technologies



VMC 6030

SPECIFICATIONS

General	Imperial	Metric
FLOOR TO TABLE SURFACE	36"	914.4 mm
MACHINE WEIGHT	17,000 lbs.	7,711 kg
CONSTRUCTION	Cast Iron Box Way X/Y/Z	
Table		
TABLE SIZE	62.5" x 30"	1,587.5 mm x 762 mm
T-SLOTS (NO. x WIDTH x SPAN)	5 x .709" x 5.512"	5 x 18 mm x 140 mm
CUTTING FEED RATE (X/Y/Z)	400 ipm max	10.16 mpm max
RAPID TRAVEL RATE (X/Y/Z)	400 ipm	10.16 mpm
MAX. WEIGHT ON TABLE	4,120 lbs. ^c	1,869 kg ^c
BALL SCREW SIZE	1.75" Dia. (X/Y) 1.5" Dia. (Z)	44.45 mm Dia. (X/Y) 38.1 mm Dia. (Z)
LONGITUDINAL (X AXIS)	60"	1,524 mm
LATITUDINAL (Y AXIS)	30"	762 mm
VERTICAL (Z AXIS)	30"	762 mm
SPINDLE NOSE TO TABLE	5.5"-35.5"	137.7 mm – 901.7 mm
SPINDLE CENTER TO COLUMN WAYS	30"	762 mm
Accuracy		
AXIS POSITIONING**	+/- .0004"	+/- .010 mm
AXIS REPEATABILITY**	+/- .0002"	+/- .005 mm
Spindle		
POWER TRANSFER	Automatic Mechanical, 2 speed VECTOR Drive	
SPINDLE SPEED	10-10,000 RPM	
SPINDLE ORIENTATION	Electromechanical	
SPINDLE TAPER	No. 40	
Tools		
ATC, NUMBER OF TOOLS	21	
ATC, TOOL SELECTION	Random / Bi-directional	
MAX. TOOL DIAMETER	3"	76.2 mm
(WITHOUT ADJACENT TOOLS)	4.5"	114.3 mm
MAX. TOOL LENGTH	15"	381 mm
MAX. TOOL WEIGHT	15 lbs.	6.8 kg
Motor		
SPINDLE DRIVE MOTOR	AC, VECTOR Drive	
HORSEPOWER	15 HP / 22.5 HP*	11.2 kW / 16.8 kW*
TORQUE	90 ft.-lbs. / 220 ft.-lbs.*	122 N-m / 298 N-m*
OPT. VERY HIGH TORQUE SPINDLE	30 HP* / 270 ft.-lbs.*	22.4 kW* / 366 N-m*
AXIS DRIVE MOTOR (X/Y/Z)	AC, 3,800 lbs.* thrust	AC, 1,724 kg* thrust
Miscellaneous		
AIR PRESSURE REQUIREMENT	80-120 PSI, 15 SCFM (Momentary)	5.5-8.3 Bar, .42m ³ /min (Momentary)
POWER REQUIREMENT (3-Phase)	63 A @ 230 VAC	
OPTIONAL SINGLE PHASE	N/A	
COOL POWER	Spindle, Y Ballscrew	

Options

- 30-Position ATC (CAT or BT)
- 24-Position DATC (CAT or BT)
- Spindle Options
 - 10,000 RPM Very High Torque (240V)
 - 10,000 RPM Air/Oil Spindle
 - 15,000 RPM Air/Oil Spindle
- Coolant thru Spindle (250 psi)
- Rigid Tapping
- Chip Conveyor System
- Flat Sheet Metal Cover
- Ship Machine Un-Caulked
- Auto Aim Servo Coolant
- 480 Volt - 3 Phase Transformer
- Additional Work Light
- Remote Manual Pulse Generator
- 32MP Control
 - Ability to Network
 - High Capacity Hard Drive
 - Shop Floor Programming
- Expanded Memory Levels
 - 422K RAM Memory
 - 4 MB RAM Memory
 - 8 MB RAM Memory
 - 16 MB RAM Memory
- 3.5" Floppy Disk Drive
- Heidenhain Glass Scales
- Renishaw Touch Probes
 - TS-27R Tool Setter Probe
 - MP-11 Probe System
 - MP-12 Probe System
- Rotary Products
 - VH-5C
 - VH-165 mm
 - VH-175 mm
 - VH-225 mm
 - VH-275 mm
 - TR-165 mm (5-Axis)
 - V-300 mm
 - V-400 mm
 - Rotary Accessories
- Midaco Pallet Changer
- Tooling Packages
 - (11) Tool Starter Package
 - (20) Tool Premium Package
 - Tooling Certificates

VMC 6030 TABLE DIMENSIONS

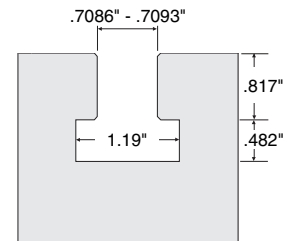
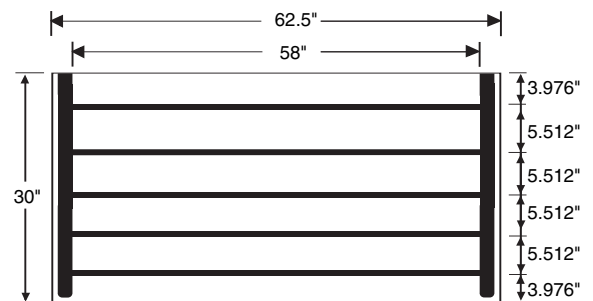

T-SLOT

^c Evenly Distributed Weight
^{*} Peak
^{**} All accuracies are quoted at 68°F.
 Fadal reserves the right to change standard and optional machine accessories.
 Extended column add 8" to height
 Continuous equivalent A-weighted sound pressure at workstation is 77 db(A) or less during normal cutting operations.

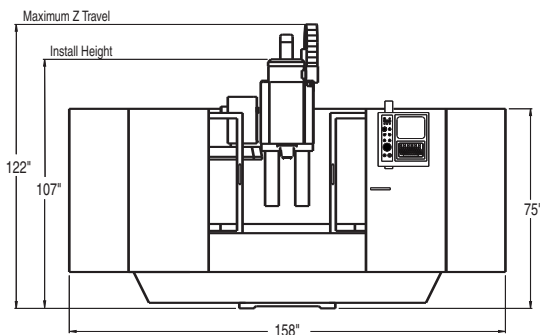

Front View

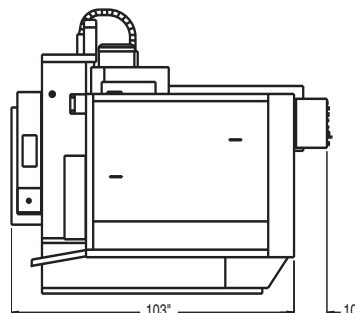

Side View

www.fadal.com



Fadal Machining Centers, LLC
 20701 Plummer Street, Chatsworth CA 91311 USA
 Telephone (818) 407-1400 • FAX (818) 407-0020